

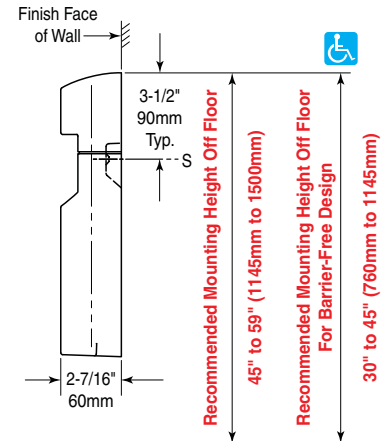

Technical Data

MatrixSeries™ SURFACE-MOUNTED SEAT-COVER DISPENSER

B-5221

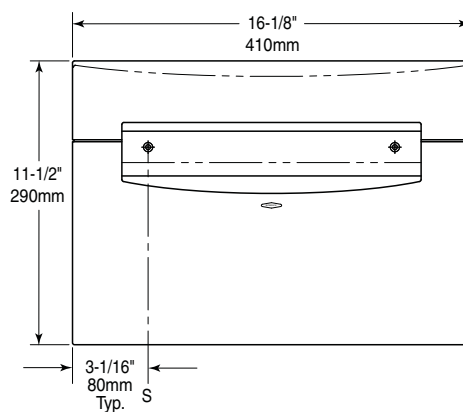

MATERIALS:

Durable, high-impact grey ABS with high-gloss finish on exposed surfaces. Front of dispenser has same degree of arc as other Bobrick MatrixSeries washroom accessories. Radius on corners, edges and top complement other MatrixSeries accessories.

OPERATION:

Dispenser holds single- or half-fold paper toilet seat covers. Dispenser fills from bottom through concealed opening. Capacity: 250 toilet seat covers.

INSTALLATION:

Mount unit on wall or partition of toilet compartment with two #8 x 1/2" (4.2 x 38mm) flat-head sheet-metal screws (not furnished) at points indicated by an S. For plaster or dry wall construction, provide concealed backing to comply with local building codes, then secure unit with sheet-metal screws. For other wall surfaces, provide fiber plugs or expansion shields for use with sheet-metal screws, or provide 1/8" (3mm) toggle bolts or expansion bolts.

Note: Provide a 5" (125mm) minimum clearance from bottom of dispenser to top of any horizontal projection to provide room for filling dispenser from bottom.

SPECIFICATION:

Surface-mounted toilet-seat-cover dispenser shall be durable, high-impact grey ABS with high-gloss finish on exposed surfaces. Front of dispenser shall have same degree of arc as other Bobrick MatrixSeries™ accessories in the washroom. Radius on corners, edges and top of dispenser shall complement other Bobrick MatrixSeries™ washroom accessories. Unit shall have a rectangular opening for dispensing toilet seat covers and a concealed opening in bottom for filling. Capacity shall be 250 paper toilet seat covers.

Surface-Mounted Toilet-Seat-Cover Dispenser shall be Model B-5221 of Bobrick Washroom Equipment, Inc., Clifton Park, New York; Jackson, Tennessee; Los Angeles, California; Bobrick Washroom Equipment Company, Scarborough, Ontario; Bobrick Washroom Equipment Pty. Ltd., Australia; and Bobrick Washroom Equipment Limited, United Kingdom.