

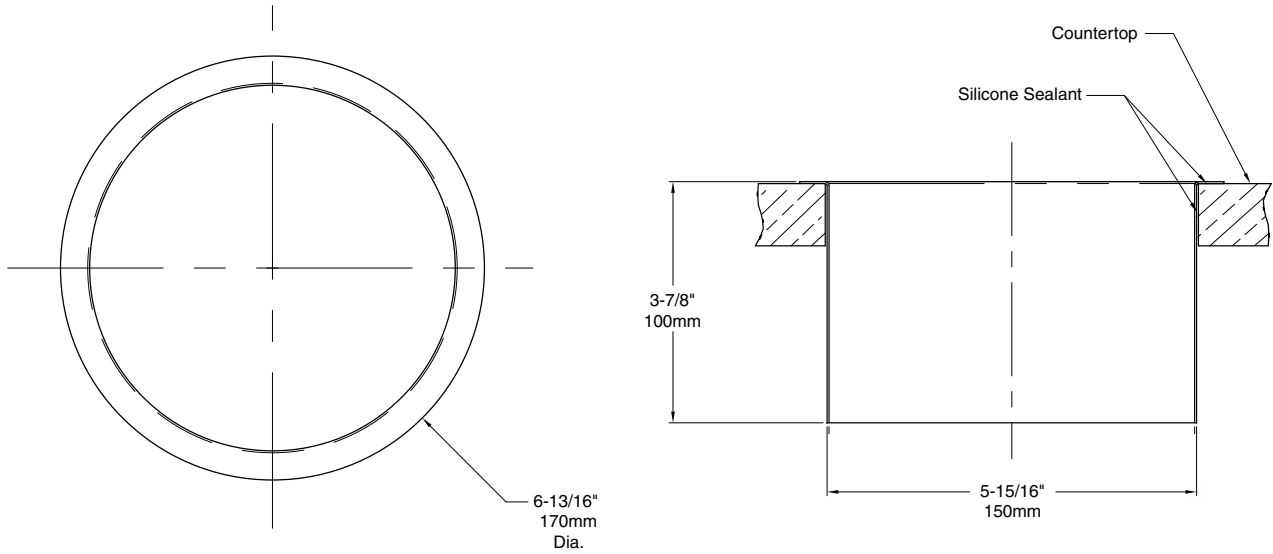

Technical Data

CIRCULAR WASTE CHUTE FOR MOUNTING IN COUNTERTOPS

B-532



Rough Countertop Opening
6-1/8" ± 1/16" (155 ± 1.5mm)

MATERIALS:

Circular Waste Chute — Type-300, 22-gauge (0.8mm) stainless steel. Exposed surfaces have satin finish.

INSTALLATION:

Unit is designed for installation in 6-1/8" ± 1/16" (155 ± 1.5mm) diameter hole in any countertop. To install unit permanently in place, cut hole in countertop. Fill in underside of waste chute lip and around portion of waste chute body which protrudes down into mounting hole with silicone sealant (not furnished). Install unit into countertop hole. Once unit is in place, wipe off any excess glue with a clean rag.

SPECIFICATION:

Circular waste chute for mounting in countertops shall be type-300 stainless steel with 5-7/8" (150mm) inside diameter, flat lip and satin finish on exposed surfaces. Waste chute opening shall provide access to deposit waste into waste receptacle (not furnished) placed under the countertop. Manufacturer's service and parts manual shall be provided to the building owner/manager upon request.

Circular Waste Chute For Mounting In Countertops shall be Model B-532 of Bobrick Washroom Equipment, Inc., Clifton Park, New York; Jackson, Tennessee; Los Angeles, California; Bobrick Washroom Equipment Company, Scarborough Ontario; Bobrick Washroom Equipment Pty. Ltd., Australia; and Bobrick Washroom Equipment Limited, United Kingdom.